

Case Histories in Ultrasonic Testing.

M. M. Gautam, V Prasad, C. Satheesh, and P.V Varde

Research Reactor Services Division
Bhabha Atomic Research Centre
yprasad@barc.gov.in

Abstract

Ultrasonic testing is one of the widely used Non-Destructive testing (NDT) methods and forms the essential part of In-Service inspection programme of Nuclear Reactors. Main application of ultrasonic testing is for volumetric scanning of weld joints followed by thickness gauging of pipelines and pressure vessels. Research reactor Dhruva has completed the first In Service Inspection programme in which about 325 weld joints have been volumetrically scanned, in addition to thickness gauging of 300 meters of pipe lines of various sizes and about 24 nos. of pressure vessels. Ultrasonic testing is also used for level measurements, distance measurements and cleaning and decontamination of certain reactor components. Two case histories are brought out in this paper in which ultrasonic testing was used successfully for identification of butterfly valve opening status and extent of choking in pipe lines in Dhruva reactor systems.

Key Words: Non-Destructive Testing, Nuclear Research Reactor, In-Service Inspection, Liquid Poison system, Drain Line Choke, Butter fly valve.

1.0 Introduction

1.1 In a nuclear reactor, safety has been given utmost importance and all systems, structures and components (SSC) have been designed and manufactured with highest standard of quality. Systematic surveillance programmes are then followed for ensuring the quality of the SSCs throughout its service. The surveillance programme verifies that the reactor is operated within the prescribed operational limits and conditions and timely detects any deterioration of SSCs that could result in an unsafe condition [1]. Dhruva is a 100MWt natural uranium fuelled research reactor, cooled and moderated by heavy water. This reactor is having an In-service inspection programme by which SSCs are inspected by different non-destructive testing (NDT) methods as per a pre decided frequency. Main inspection methods include

Visual Testing (VT), Liquid Penetrate Testing (LPT), Eddy Current Testing (ECT), Magnetic Particle Testing (MPT), Ultrasonic Testing (UT) etc.

1.2 Inspection of weld joints and heat affected zones of pipelines and pressure vessels form a major part of inspections and ultrasonic testing method is used primarily for this purpose. Presence of radioactive fluids and requirement of accessibility of two sides for keeping source and film makes Radiographic testing method less desirable. In addition to volumetric examination of weld joints, ultrasonic method is used for thickness gauging of the pipe lines and pressure vessels to estimate corrosion rate. In the first ISI campaign of Dhruva, 325 nos. of weld joints and heat affected zones of different sizes were scanned volumetrically and thickness gauging done on 300 metres of pipe lines and 24 nos. of pressure vessels. Measurements of distances remotely in

radioactive areas, level measurements inside closed tanks and cleaning/decontamination of reactor components in ultrasonic baths are the other application of ultrasonic in Dhruva reactor.

Two case histories are brought out in this paper which highlights the useful applications of ultrasonic in operating plants.

2.0 Case histories:

2.1 Process Water / Sea water (PW/SW) Hx #5 outlet valve.

Dhruva reactor has got 6 nos. of Process water/Sea water heat exchangers to transfer reactor heat to sea water system. These heat exchangers are installed in parallel across two headers (CS 900 mm dia. sea water side)(fig.1)Chain & wheel operated butterfly valves are provided on either side of heat exchangers for isolation. These heat exchangers are not provided with individual flow measuring instruments, though individual temperature and gross flow measuring instruments are available. There was a case of reduced differential temperature of process water across one of the heat exchanger (PW/SW Hx #5) in



Fig.1-Chain & wheel operated butterfly valve

comparison to other online Hxs. Reason suspected was the reduced sea water flow through the heat exchanger#5. Though all the valve positions were checked to be as intended by its position indicators, doubts were expressed about the disengagement of outlet butterfly valve disc from its actuator resulting in incomplete opening. It was required to know the exact location of butterfly valve disc in *as it is* condition without disturbing the operation of the system in order to plan the maintenance activities.

On a walk-down of the site, the valve and adjacent areas were found accessible and pipe surfaces observed to be good. Ultrasonic method was considered and felt feasible for finding the butterfly valve disc position.

Valve details

Four stainless steel butterfly valves are flange type and size of 450mmØ with holes equally spaced for bolting to the mating flange (Fig. 2). The seat ring is secured to the valve body and sitting surface is machined at an angle allowing the disc to swing through its arc. The valve disc is of slab type. It is secured to the shaft by three shear pins- two in the drive shaft and one in the non drive shaft. The drive shaft extends from the body and this fitted with a key to suit the drive from the driving unit. The valve is manually

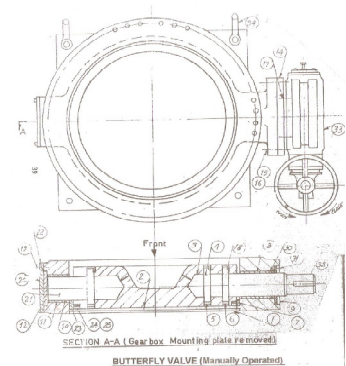

operated with Fig. 2 Valve internals a gear and chain wheel arrangement. Drive mechanism is provided with a mechanical

three position pointer and dial clearly showing the valve position as fully close at zero degree, fully open at 90 degree and intermediate positions.

Main limitations in devising testing method were;

- 1) Bio fouling on the inner surfaces due to sea water,
- 2) Higher pipe diameter with rubber lining,
- 3) Deciding probe sizes, location and testing parameters.

As the line is in the vertical direction and located below heat exchangers, it is expected that the line will run full mostly. Hence, through transmission and pulse echo methods [2] could be tried, however it was observed that pulse-echo method was giving good quality echo signals with increased gain only. Clear back wall echo signal was observed at length(water path) equivalent to pipe diameter indicating the path is free. Hence the methods were applied to locate the point at which the echo was reduced indicating the beam is intercepted. As indicated in the sketch, when the butterfly valve reaches its fully open position, its tip will be 230mm distance from the center (mid point between the flanges) of valve body and if it is partially opened, the tip will be near to its centre (<230mm).

Mock-up trials

Mock up trials were carried out using Panametric make Epoch-4 ultrasonic flaw detector, EEC make normal beam 2.25 MHz., 16 mm Ø sensor on a 450 mm Ø CS pipe segment filled with service water. During the trials, both the pulse-echo and

through transmission techniques were able to produce good quality signals and were able to identify a CS plate obstruction inside the water filled pipe.

Site Testing and observations:

Site testing was carried out initially by employing pulse echo method with scanning of sea water outlet line of Hx #5 at different elevations on either side of the valve. Similar scanning was also carried out in Hx. #4 for comparison purpose. Upstream side testing indicated weak signals, probably due to bio fouling inside or liner degradation and hence downstream side was used for scanning. Back wall echo appeared beyond a distance of 230 mm from the centre of the valve for Hx #4 (Fig. #3 a & d) while it was beyond 200 mm for Hx. #5 (Fig. #3 c & d). An intermediate echo was also observed within

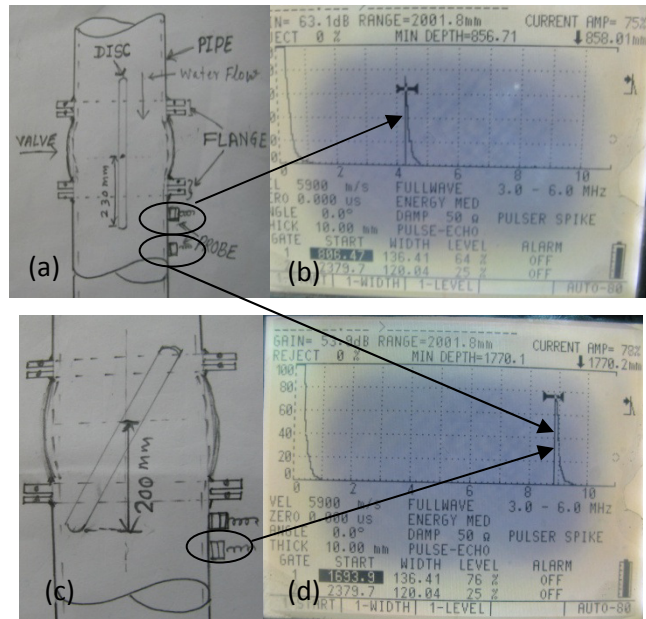

230 mm from the centre of the valve
 Fig.3, a & c – Probe positions on the downstream of the valve; b- Echo when sensor put within 230 mm of fully open valve; d –Echo when sensor put beyond the flapper disc either full or partial open

for Hx. #4 (Fig. 3 b), while no such echo signal was noticed in case of Hx #5 valve. When through transmission technique was tried, a clear water path echo also appeared beyond 230 mm for Hx. #4 and at 200 mm for Hx. #5. Loss of water path echo before 230 mm for Hx#4 and before 200 mm for Hx#5 ensured the availability of clear path inside. This testing required proper aligning the two sensors diametrically opposite sides. This conclusively proved that Hx#5 outlet valve opened upto maximum of 200mm from the centre as against the normal of 230mm. Subsequently, on dismantling the valve, its locking key of the disc shaft with drive mechanism found disengaged and valve position was remaining in partially open condition.

After repairing the valve disc, the same method was again tried for various valve openings and the observations indicated that the trajectory of valve tip could be correctly identified by the above two methods beyond flange locations.

2.2 Emergency Shutdown System (ESD)

Emergency Shutdown System (ESD) of Dhruva reactor consists of twenty poison tubes, top and bottom headers, buffer tank, poison storage tank, valves and associated pipe lines of various diameters (Fig. -4). To keep the system healthy and dry, He/N₂ gas purging is carried out regularly. There was a case of increased radiation field in the poison storage tank room. Also while carrying out of flushing of line through drain line, no helium gas was coming out from the downstream side of the drain valve #27 (Fig. 4). All valve line up was checked to be as desired. It was required to identify the reason for blockage of Helium flow and increased radiation field.

The drain lines are of 40 mm dia and made of stainless steel. The outer side was clean and accessible for inspection. As the purge gas flow could not pass through, tight plugging of the line was suspected from the inner side and an ultrasonic method was considered for detecting the choking in the line. When a preliminary normal beam testing of the line was taken up in the area where high radiation field was observed, water path signals could be observed at some locations when instrument ranges was fixed at 500 mm. This indicated

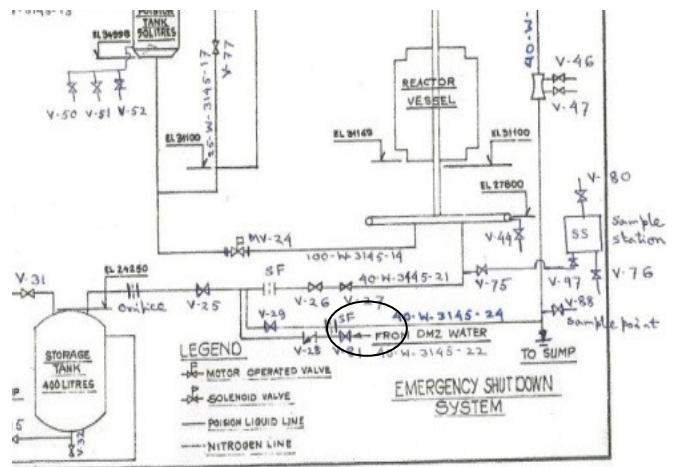

Fig 4. Flow diagram (part) of ESD presence of water in those areas.

Mock-up trials:

Mock-up trials were organized using Perspex shoes suitable for 40 mm Ø pipe and 16 mm Ø, 2.25 MHz sensor. An SS pipe segment of about one meter length closed at one end (Fig.-5) was utilised for calibration and trials along with M/s Panametric make 'Epoch-4' UT flaw detector. Both through transmission and pulse echo techniques were utilised during the trials in following three conditions;

- Empty Pipe,
- Pipe filled with Water and

c) Pipe filled with fine sand and water
 Empty pipe showed only wide banded echoes/noise signal (Fig 6 a). Water filled pipe showed the echoes at water path distance approximately 148 mm (Fig 6b). The pipe filled with fine sand and water showed echo amplitude of 15-20 % FSH (Full Scale Height) at 138 mm approximately (Fig 6 c).

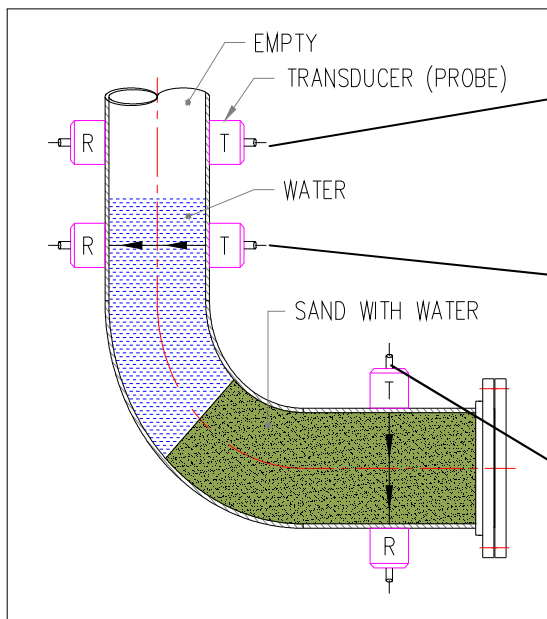
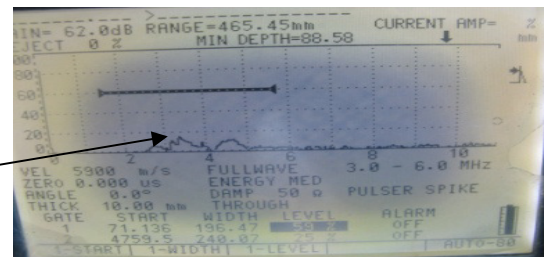

Fig.5 - Pipe filled with fine sand and water

Site Testing and observations:
 The inspection was carried out in two phases. Initial trials were done to locate areas where good echoes of water path were obtained by scanning upstream side of the valve #27 marked in Figs. 4. Clear signals started appearing on the vertical portion of the line after a height of 2' from the elbow (Fig. 7). This indicated the bottom level of the holdup water below which obstructions (blockage) could be present. In the next phase, the blockage area was scanned downwards using 2.25 MHz sensor. The amplitude of ultrasonic echo

from the above level (2' above the elbow) reduced to <10% of FSH. Similar signals were obtained till the valve end showing the extent of blockage. Both pulse-echo and through transmission methods gave similar observations. The above observations conclusively identified the location and the



(a) Echo from empty piped

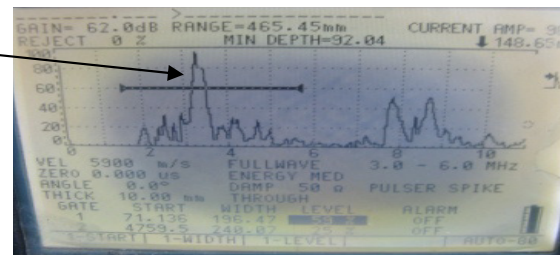

(b) Echo Through water

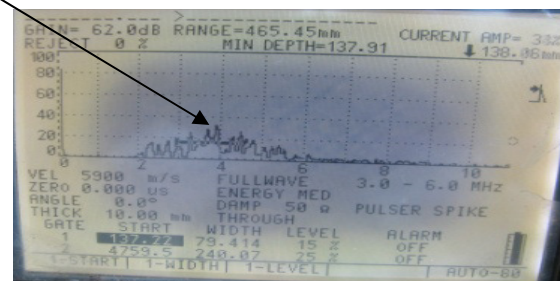

Fig. 6 (c) Echo through sand



Fig. 7 Choked line in the extent of the line.

Subsequently, pipe line was opened and choking material was removed.

3.0 Conclusion:

The above case histories indicate the non conventional uses of ultrasonic methods in operating plants. Similar testing can be utilised for other plants in-situ also depending upon the site conditions.

Authors are thankful to the Reactor Group for entrusting the above jobs and granting permission to publish the work. Authors are also thankful to In-Service Inspection Section staff for carrying out of the different measurements as and when required.

Reference:

[1] Dhruva In-Service Inspection programme. Reactor group, Bhabha Atomic Research reactor, Government of India. Revision R0; February-2011.

[2] Ultrasonic testing of materials at level-2; Training Manual for non-destructive testing techniques; IAEA Techdoc462; IAEA Vienna 1988.

Acknowledgment